

Operation and Maintenance Manual of

Halo-2000 Generator

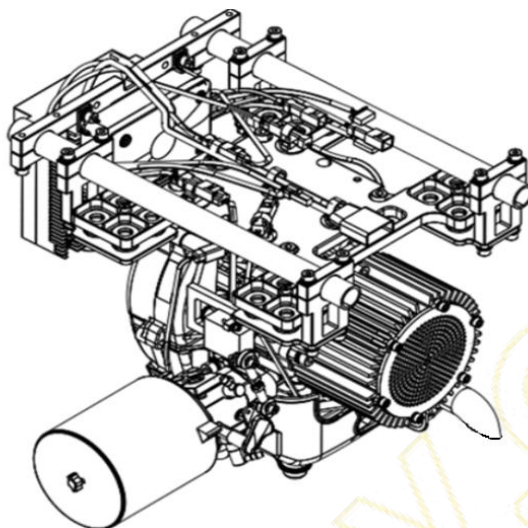

Contents

Chapter	Subject	Page
	Safety Code -----	2;
1、	Preface -----	2;
2、	Functions and Technical Features-----	2;
3、	Main Technical Parameters -----	3;
4、	Wiring Diagram -----	4;
5、	Operation -----	5;
6、	Maintenance -----	11;
7、	Faults and Maintenance Methods-----	13;
8、	Transportation and Storage-----	14;
9、	Unpacking Instructions -----	14;
	Appendix 1: List of Accessories -----	14;

Safety Code

Before using this product, please read this manual carefully and be familiar with the meaning. Only by correctly operating and maintaining the product can we ensure its safe and effective operation. In case of any irresistible accidents such as disability, death, fire and so on due to improper use, it has nothing to do with the product and the manufacturer. If the user refits, all irresistible accidents after refitting have nothing to do with the manufacturer.

General safety precautions:

- When disassembling the motor and control system, cut off the power supply first.
- The motor shall be kept clean and free from obstacles. All dirt on the motor shall be cleaned regularly to keep the motor clean and dry.
- Exhaust gas discharged by the engine has certain toxicity, and do not inhale or contact engine exhaust gas.

This manual is an important part of the system. Without written approval, it is strictly forbidden to copy any content of this manual.

Chapter 1 Preface

First of all, thank you for your trust in our brand! Welcome to use the aviation hybrid system (UAV) provided for you. Please read this manual before you use it.

This manual provides guidance on the use, troubleshooting and maintenance of Halo-2000 Generator aviation hybrid system.

This manual does not provide maintenance guide for electrical components. When it is determined that the electrical components have failed, please do not repair them. The whole assembly must be replaced. Other damage may be caused by trying to repair the faulty electrical components.

Please read the safety rules in this manual carefully and follow all the requirements and precautions in this manual.

Chapter 2 Functions and technical features

According to the requirements of multi rotor UAV, the Halo-2000 Generator aviation hybrid system developed by us is a 48V (12sli battery) hybrid system.

The engine is powered by a single cylinder and two-stroke gasoline engine, which has the characteristics of high output power and low fuel consumption. The motor adopts an integrated internal rotor motor, which is integrated with the engine, so that the hybrid system has the advantages of small volume, light weight, low noise and high mass power ratio. The controller has the protection functions of overcurrent, overvoltage, overtemperature, undervoltage, short circuit and overspeed. Halo-2000 Generator hybrid system has the advantages of excellent quality, strong power source, long-time high-power output and long endurance.

Chapter 3 Main technical parameters

3.1 Halo-2000 Generator Main Technical Parameters are listed in Fig. 1:

Fig. 1:

No.	Items	Unit	Parameter Index	Remarks
1	Rated Voltage	V	48	
2	Rated Power	KW	1.8	
3	Weight	kg	4.5	
4	Dimension (L x W x H)	mm	282×265×256	
5	Average Fuel Consumption	L/h	1.65	
6	Applicable Models		Multi-rotor	
7	Applicable MTOW	kg	19	
8	Applicable Power Voltage	VDC	48V(12S)	
9	Altitude	Km	≤1.5	
10	Operating Ambient Temperature	°C	-20 ~ 55	
11	Start Mode		automatic start and stop	
12	Mixing Ratio of Lubricating Oil and Gasoline		25:1	



Caution : Please confirm that the technical parameters of UAV match the parameters of this hybrid system before use, so as to meet the operational performance of UAV, Prevent damage caused by improper configuration.

Chapter 4 Wiring Diagram

4.1 Wiring: The wiring with the aircraft terminal is shown in Figure 1

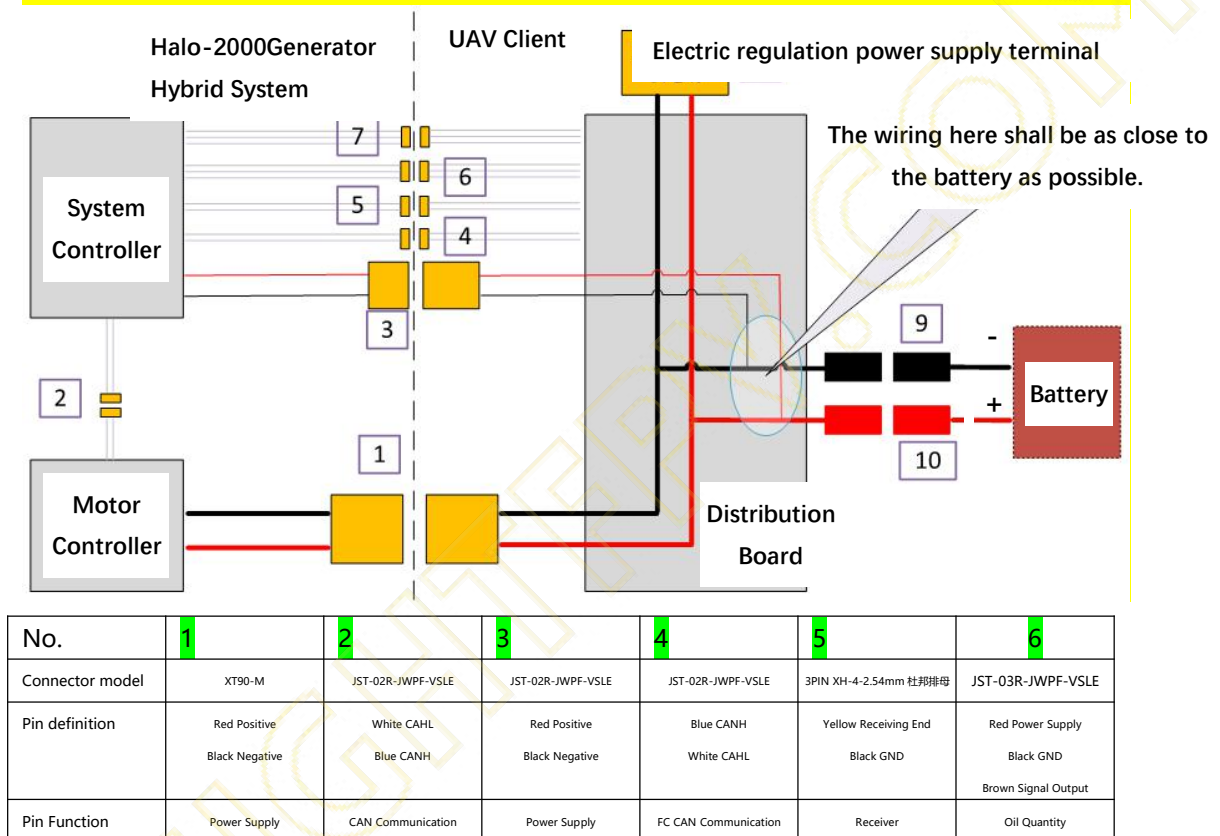

Fig 1



- 1) : When the system is powered on, please ensure that No. 1-9 connectors are connected, and finally connect No. 10 connector (positive end of the battery). Illegal operation will cause damage to the controller;
- 2) Two independent connectors shall be used at the battery end, as shown in the figure. No. 9 and No. 10 connectors are not equipped with anti ignition function inside the hybrid system. No. 10 connector shall be anti ignition connector;
- 3) The battery harness shall not be too long, and the power supply line of the system controller in the distribution board shall be close to the battery end as far as possible;
- 4) 4) The whole hybrid system is not equipped with low power consumption function.

Please remove the battery after use.

4.2.1 Serial port harness connection

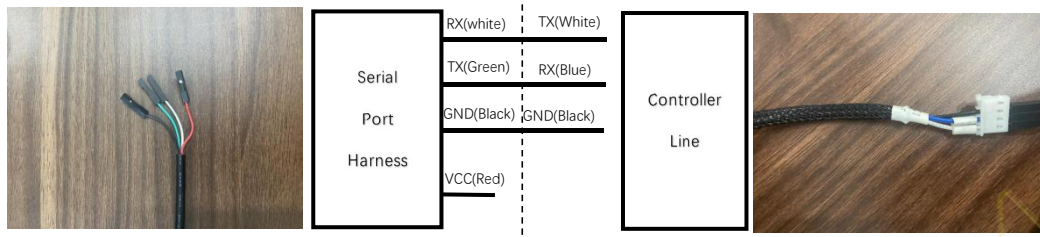

4.2.2 Software installation instructions

① Open the software installation package, which contains two folders

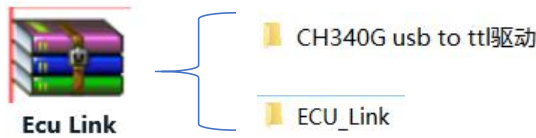

② Open ECU_Link folder, find setup.exe, double-click the installation, enter the interface as shown in the figure, and wait for loading;

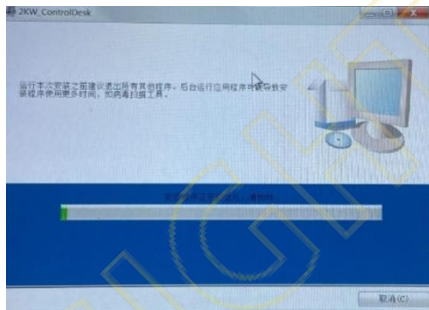

③ After loading, the following interface is displayed, change the save directory, click Next (click "next" three times in a row), and finally click finish.

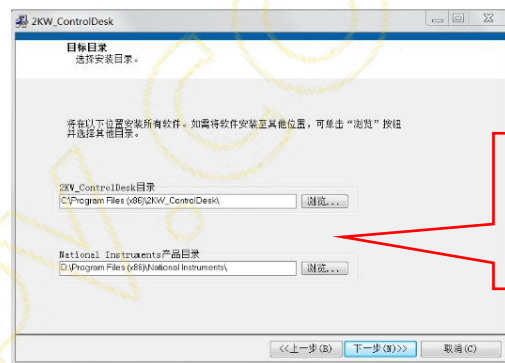

You can change the save directory here.

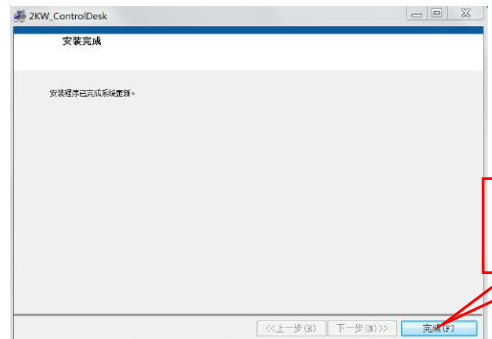

Click Complete installation

4.2.3 Open the software, and the operation interface is shown in Figure 2 below:

Locate the desktop program ECU_Double click link.exe to enter the operation interface.

If the serial port resource cannot be found, install the ch340g USB to TTL driver in the compressed package and try again.

The screenshot shows the ECU_Link software interface with the following components:

- Serial Port Resource:** A dropdown menu showing 'COM6' and a '打开串行口' (Open Serial Port) button.
- Remote control:** Three indicator lights.
- Monitoring Panel:** A central area with a red dashed border containing various data fields:
 - 启动时间(s): 0
 - 节气门位置(%): 0
 - 发动机转速(rpm): 0
 - 油位(%): 0
 - 控制器温度(°C): 0
 - 发动机温度(°C): 0
 - 电机温度(°C): 0
 - 系统电压(V): 0
- Alarm Panel:** A green '关闭报警' (Close Alarm) button and a list of fault indicators:
 - 发电机过流
 - 电压过高
 - 电压过低
 - 发电机控制器过温
 - 启发电机故障
- Bottom Panel:** A '文件路径' (File Path) field, a folder icon, a '记录文件' (Record File) button, and a '退出' (Exit) button.

Four callout boxes provide the following instructions:

- Step 1:** click the serial port resource drop-down button, select the current serial port, and then click open serial port;
- Step 2:** select the current file location for recording, determine the file path, and click start recording to record data;
- Step 3:** if there is a fault after power supply, click to clear the fault. If it cannot be cleared, the system cannot be started (it needs to be closed manually), and professional personnel need to be contacted for treatment.
- Step 4:** if there is any abnormality during operation, an alarm will be prompted here. Click Close alarm to close the prompt (the abnormality will not be cleared)

Fig 2

Chapter 5 Use operation

5.1 The outline of Halo-2000 Generator hybrid system is shown in Figure 3 below:

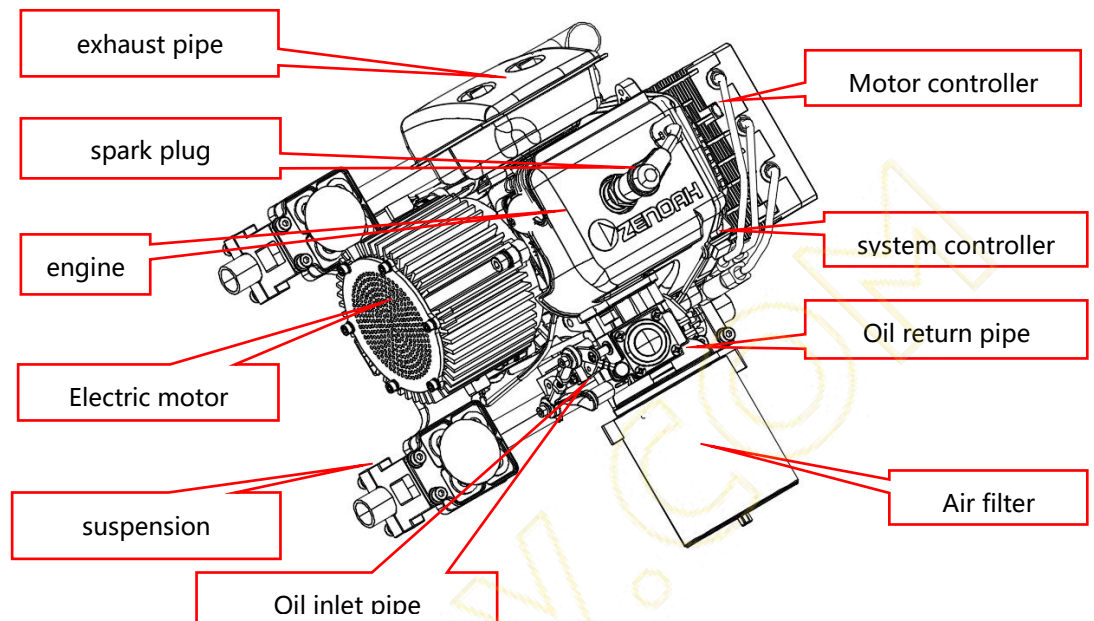

Fig 3

5.2 The installation dimensions of aviation hybrid system Halo-2000 Generator are shown in Figure 4 below:

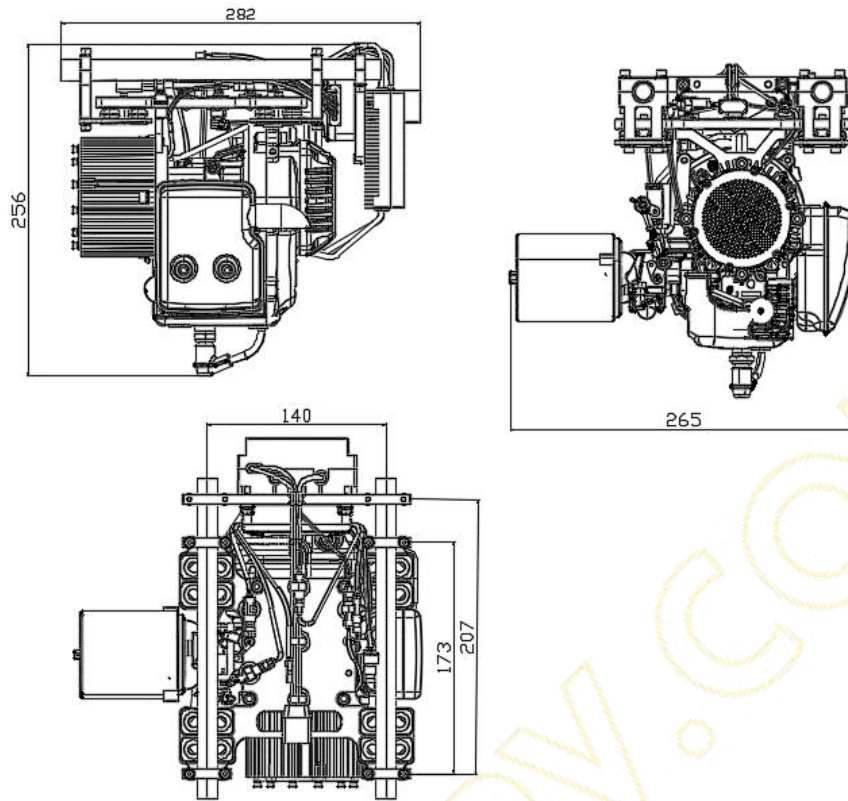

Fig 4

5.3 Installation mode

5.3.1 Install the hybrid system to the appropriate position of UAV, and the default is hoisting as shown in Figure 5 below:

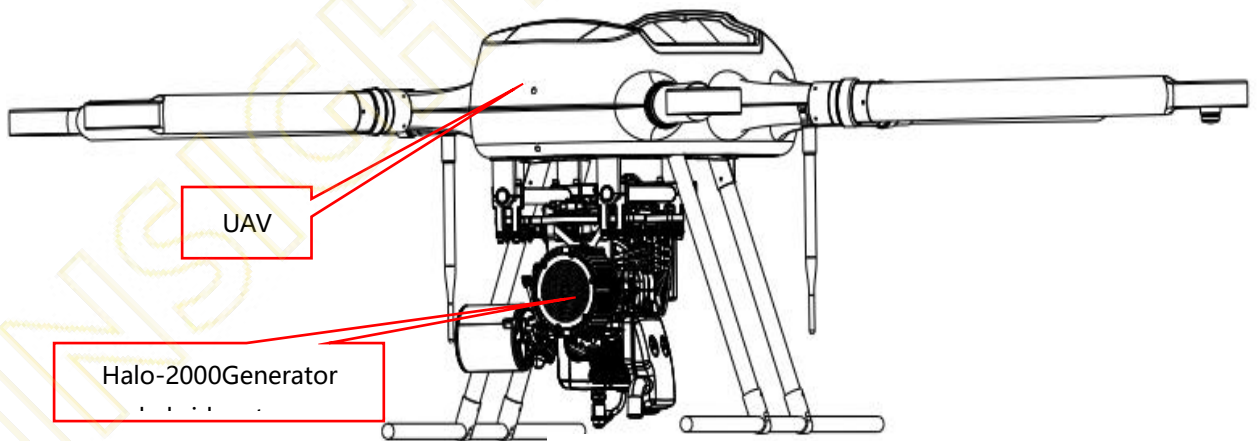



Fig 5

 : The factory default is hoisting, and other installation methods will cause damage to the shock absorber.

5.3.2 The oil circuit connection mode is shown in Figure 6 and Figure 7 below:

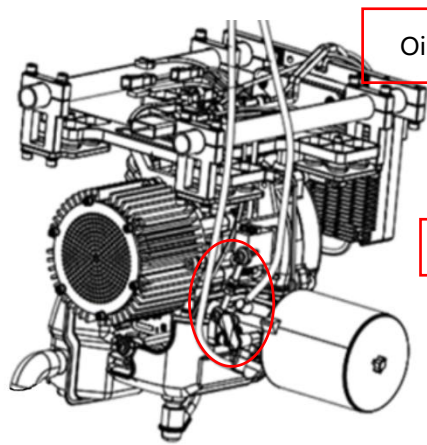

Fig 6

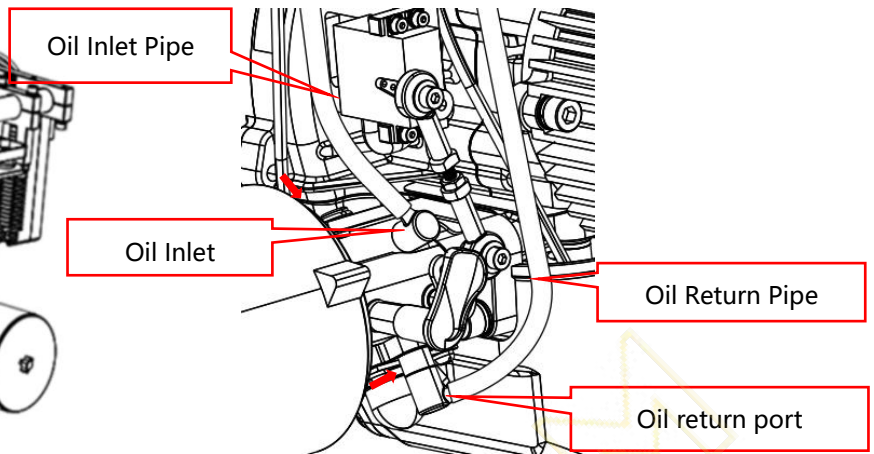

Fig 7

5.4. Preparation method of gasoline and lubricating oil

Use 95# or higher grade gasoline, Jaso FC grade or iso-l-egc grade or higher 2T engine oil (Motte 710 is recommended), use a proportioning pot and prepare it according to the engine fuel ratio of 25:1 (gasoline: engine oil). It is strictly prohibited to use vehicle 4-stroke engine oil; The specific preparation steps are shown in Figure 8 below.

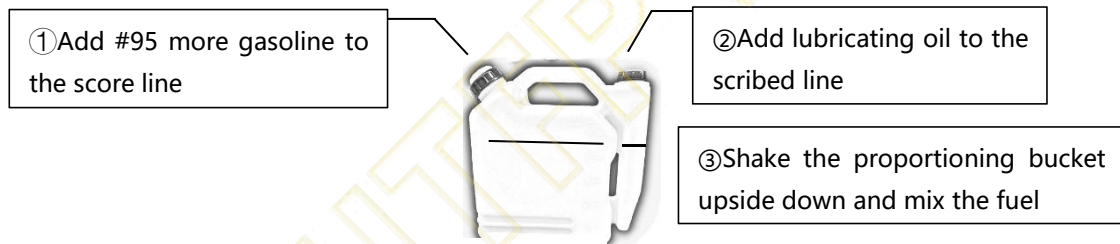

Fig 8

5.5 Inspection items before use

- 5.5.1 Check whether the connectors of the system and controller are connected and installed in place.
- 5.5.2 Check whether there is enough fuel in the oil tank and whether the fuel pipe is connected correctly.
- 5.5.3 Spark plugs shall be checked before use. Spark plugs with excessive carbon and oil stains shall be replaced or cleaned.
- 5.5.4 Check the steering gear mechanism and check whether the steering gear pull rod ball joint rotates flexibly. If it is stuck, it needs to be repaired.
- 5.5.5 Check the position of steering gear and throttle, and check whether the steering gear operates normally and whether the throttle position is correct.

5.5.6 Check the motor and check whether the motor rotates normally.

5.5.7 Check the oil pipe. The oil pipe shall not directly contact with heat sources such as engine or motor, and avoid excessive bending of the oil pipe.

5.6 Precautions for starting the engine

5.6.1 Before starting the engine, press the transparent oil bubble on the carburetor by hand (as shown in Figure 9) to make the oil inlet pipe full of oil and free of bubbles;

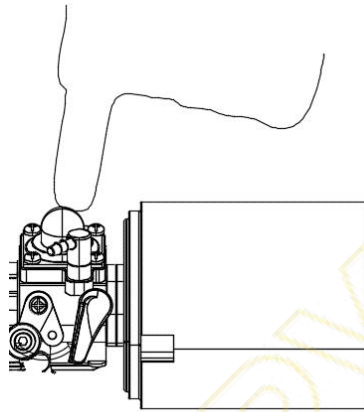

Fig 9

5.6.2 After the engine is started, the idle speed must be maintained for 30s to make the crankshaft, piston and connecting rod more fully lubricated;

5.6.3 Failure to start for many times may cause the spark plug to be flooded. In this case, replace or dry the spark plug and try to start again;

5.6.4 When starting the cold engine, close the choke. After starting the idle speed, open the choke (as shown in Figure 10). When starting the hot engine, it is not necessary to close the choke.

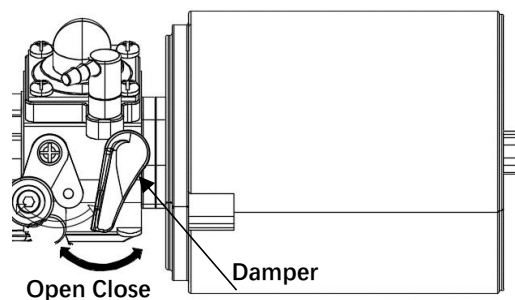

Fig 10

5.7 Operation (Mode 1: Two-Key Control)

5.7.1 R system controller receiver signal pulse width definition

- 1) Receiver sending pulse width, 1.1ms (reserved), 1.5ms (start, idle 30s) and 1.9ms (stop), cycle 20ms:
- 2) The remote controller is equipped with a three position switch (1.1ms is idle and not used).

<p>① Start or idle:</p> <p>First, turn the three position switch of the remote control to the "superscript" position, then turn it from the "superscript" position to the "subscript" position, pause for 2 seconds, and then turn the three position switch of the remote control to the "bid winning" position to start the hybrid system (if it is not started, repeat the above methods).</p>
<p>② Power generation operation:</p> <p>After the engine is ignited and idling, the hybrid system does not need any manual operation. After 30s warm-up protection, the system automatically enters the power generation state.</p>
<p>③ Shut down:</p> <p>When the hybrid system is in the idle running state, turn the three position switch of the remote control from the "bid winning" position to the "subscript" position to stop, the system reduces the speed, enters the 30s shutdown idle running state, and stops automatically after 30s.</p>



Subscript: shut down	Middle: start and idle operation status	Superscript: reserved
--------------------------------	------------------------------------------------------	---------------------------------

Fig 11

5.7.2 To start the Halo-2000 Generator aviation hybrid system, please first confirm whether the three position switch of the remote control is normal.

5.7.3 Turn the position-control switch of the remote control to the "middle" (as shown in Figure 11) position for idle operation,

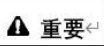
Observe the bus voltage and  **重要** ensure that the bus voltage is stable at 48V ± 2V.

5.7.4 Observe the bus voltage and operate stably for about one minute to warm up the engine.

5.7.5 In case of maneuver or gust during flight, the bus voltage will drop to 46v, which is a normal phenomenon.

If the bus voltage drops rapidly and continuously and is lower than 45V, special attention shall be paid, and it shall be lowered immediately for maintenance if necessary.

 **重要** Halo-2000 Generator can be equipped with about 90 second emergency landing lithium battery (lithium battery specification, 1850mah, 12s Grignard aircraft

model battery). If you need a longer landing time, please contact the manufacturer.

5.7.6 Fuel depletion during operation will cause serious damage to Halo-2000 Generator aviation hybrid system, and the optional oil level can be used

The sensor monitors the amount of remaining fuel to ensure that it stops running before the fuel runs out.

5.8 Operation mode 2: Three-Key Control

5.8.1 System controller receiver signal pulse width definition

- 1) The receiver sends pulse width, 1.1ms (power generation operation), 1.5ms (startup and idle operation status) and 1.9ms (shutdown), with a cycle of 20ms:
- 2) The remote controller is equipped with a three position switch. First confirm that the remote controller switch is in the "superscript" position, as shown in the figure.

1、 Starting or idling:

First, turn the three position switch of the remote control to the "superscript" position, then turn it from the "superscript" position to the "subscript" position, pause for 2 seconds, and then turn the three position switch of the remote control to the "bid winning" position to start the hybrid system (if it is not started. repeat the above methods).

2、 Power generation operation:

After the engine is ignited and idling, turn the remote control to the "superscript" position to enter the power generation state.

3、 Idle operation:

When the hybrid system is in the power generation operation state, turn the remote control switch from the "superscript" position to the "bid" position to enter the idle state.

4、 Shutdown:

When the hybrid system is running at idle speed, turn the three position switch of the remote control from the "bid winning" position to the "subscript" position to stop. enter the shutdown state and stop the hybrid system.



Subscript:
shut down

Middle:
start and idle
operation status

Superscript:
Power
generation

图 12

5.8.2 To start the Halo-2000 Generator aviation hybrid system, please first confirm whether the

three position switch of the remote control is normal.

5.8.3 Turn the three position control switch of the remote control to the "bid winning" (as shown in Figure 12) position for idle operation,

Observe the bus voltage,  **重要** Ensure that the bus voltage is stable at 48V ±

2V.

5.8.4 Observe the bus voltage and operate stably for about one minute to warm up the engine.

5.8.5 In case of maneuver or gust during flight, the bus voltage will drop to 46v, which is a normal phenomenon.

If the bus voltage drops rapidly and continuously and is lower than 45V, special attention shall be paid, and it shall be lowered immediately for maintenance if necessary.

5.8.6 Fuel depletion during operation will cause serious damage to Halo-2000 Generator aviation hybrid system, and the optional oil level can be used

The sensor monitors the amount of remaining fuel to ensure that it stops running before the fuel runs out.

5.9 Stop operation

5.8.1 After continuous flight, Halo-2000 Generator system needs to be cooled. Therefore, after landing, please turn the three position control switch of the remote control to "Middle"(as shown in Figure 11), the system will automatically idle for 30 seconds, and the system will automatically shut down after 30 seconds.

5.8.2  **注意** After the booster runs, some parts are at high temperature. After the booster stops running, please do not touch the booster to avoid scalding.

5.8.3 Hint



Gasoline is a volatile flammable and explosive liquid. At the end of the task

or during long-distance transportation, the remaining fuel in the mailbox shall be drained and properly stored in the oil barrel to avoid danger!

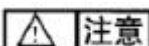

Sudden power outage is prohibited during machine operation, otherwise

the controller will be shut down

Chapter 6 maintenance

6.1 Routine maintenance items (after each operation)

6.1.1 Check whether the controller circuit plug is in good contact and whether the oil pipe is loose;

6.1.2 Check whether the controller is damp and keep it dry;

6.1.3 Check the motor for dirt and moisture, remove the dirt and keep it clean and dry;

6.1.4 Check the air filter, remove dirt and keep it clean;

6.1.5 Check whether the fixing bolts are loose, and no loose bolts are allowed;

6.2 Regular maintenance

6.2.1 After the first operation time of Halo-2000 Generator aviation hybrid system reaches 25h, clean the air filter and check the carbon deposit on the spark plug (if the carbon deposit is serious, remove the carbon deposit); In the future, the carbon deposit on the spark plug must be removed after every 25h of operation, and the spark plug with excessive carbon deposit and oil stain shall be replaced. Check the gap between the center electrode and side electrode of the spark plug, adjust the gap to 0.6 ~ 0.7mm, the installation torque of the spark plug is $10.8 \pm 2n$. M, and the head of the ignition coil shall be pressed tightly;

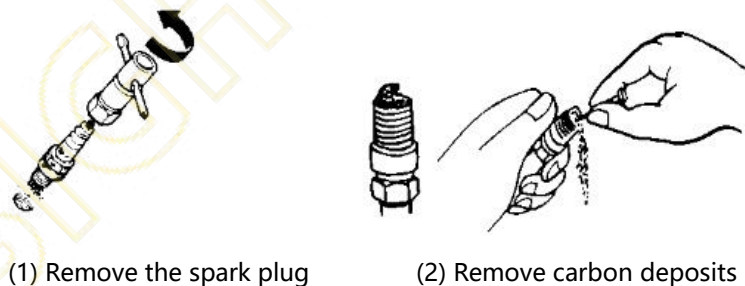

Fig 12

6.2.2 It is recommended to replace the air filter after 50h operation of Halo-2000 Generator aviation hybrid system (if the operation environment is bad, increase the replacement frequency);

6.2.3 Check whether the fuel pipe has aging, hardening and cracks. If so, be sure to replace it to avoid potential safety hazards.

6.2.4 Check whether the motor has dirt, remove sundries and keep it clean and dry, maintenance in the Fig.2.

NAME	Before startup	25h	50h	75h	100h
• FILTER	check	clean	change	clean	change
• OIL	check	check	change	check	change
STEERING	check	check	change	check	change
SPARK PLUG	check	check	change	check	change
STEERING LINKAGE	check	check	check	check	change
OIL INLET PIPE	check	check	check	check	change
OILRETURN PIPE	check	check	check	check	change
EXHAUST PIPE BOLT	check	check	check	check	check
STEERING BOLT	check	check	check	check	check
SUSPENSION	check	check	check	check	change

Fig. 2

6.3 Maintenance before long-term shutdown

If Halo-2000 Generator aviation hybrid system is disabled and not used for a long time.

Before storage, the system needs to be fully maintained to avoid the failure of some parts due to long-term shutdown and maintain the system performance.

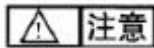

The manufacturer shall not bear any responsibility for system damage

caused by failure to maintain on time.

Chapter 7 Faults and maintenance methods

7.1 See Table 3 below for common faults and maintenance methods:

Tab 3:

No.	Fault description	Inspection items	Cause of failure	Maintenance method
1	The system cannot be started	Receiver signal matching remote control switch	No idle control switch	Turn the control switch to the "idle" position.
2			Controller not powered	Check whether the battery plug and voltage are normal.
3		Air filter	Carburetor blocked	Repair carburetor.
4			Poor service environment	Clean the filter element with fuel.

5		Oil supply system	Wrong lubricating oil model	Replace the original lubricating oil.	
6			Oil pipe bubble or no oil	Press the oil bubble several times to absorb oil.	
7		Wire harness	Poor connector contact	Check the line and reconnect it.	
8		Intake system	Damper not open	Open the carburetor damper.	
9		spark plug	Ignition yellow or weak	Replace spark plugs.	
10		Motor harness	The phase sequence of the three-phase line is wrong, causing the motor to reverse.	Exchange any two phase lines.	
11		Speed fluctuation, voltage fluctuation, smoke	spark plug	Loose spark plug	Tighten spark plugs.
12			fuel	Fuel water or fuel quality Poor fuel quantity and fuel storage for more than 2 months	Replace the fuel
13			Lubricating oil	Poor quality of lubricating oil	Replace the original lubricating oil
15			Oil circuit	The oil supply is not smooth, there are bubbles in the yellow oil pipe, or the oil filter in the oil tank has not been replaced for more than 50 hours.	Press the oil bubble repeatedly to squeeze out the bubbles in the oil pipe, ensure that the oil tank is connected with the atmosphere, or replace the oil filter in the oil tank (white wool).
16		control circuit	The control circuit or sensor is damaged.	Contact the manufacturer.	
17	Insufficient output power	Engine	The maintenance period has expired.	Contact the manufacturer.	
18		Air filter	Dirty air filter element	Clean the filter element with gasoline.	
19		carburetor	Carburetor blocked	Cleaning (as follows).	
20		spark plug	Remove the spark plug, press		

			it into the red coil, contact the ignition head of the spark plug with the engine block, and turn the starting head. If the ignition is yellow or weak, replace the spark plug.	
21	The voltage drops rapidly after takeoff	Battery	Battery voltage too low	Turn the three position switch to "run" before takeoff and wait for about 1 minute.
22	others		Damage to mechanical parts	Contact the manufacturer.

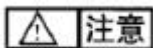

The system does not support low power consumption. When users do not use the system, they need to remove the battery or cut off the electrical connection

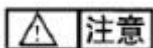

between the battery and the system by setting a switch;

The system does not support hot plug. When users use and maintain, hot plug the controller connector will damage the controller;

7.2 The carburetor is blocked and the output power is insufficient due to the use of environment (dust) or fuel oil filtration. The fault can be eliminated by simply cleaning the carburetor. The operation steps are as follows.

7.2.1 Remove the carburetor cover screw (1), open the carburetor cover, and clean the diaphragm, oil inlet and small hole with carburetor cleaning agent.

7.2.2 Remove the oil bubble screws (4 PCs.), open the lower cover, press and hold the carburetor valve, and clean the valve and surrounding gaps with carburetor cleaning agent.

7.2.3 Reinstall the oil cover to ensure that the sealing gasket and diaphragm are installed in the correct direction.

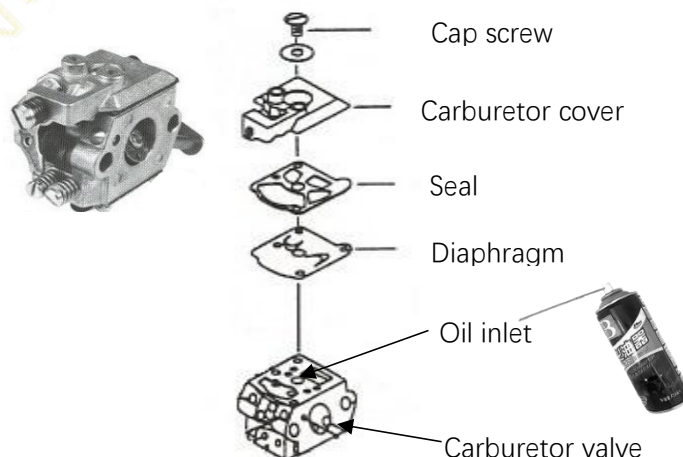

Fia 13

Chapter 8 Transportation and storage

Handle with care during loading and unloading. It is forbidden to bump and scratch during transportation to prevent rain forest. The booster shall be stored in a clean, ventilated, moisture-proof and moisture-proof place.

If idle for a long time:

- 1) Please place the booster in a clean, ventilated, moisture-proof and moisture-proof place;
- 2) Disconnect the controller power cord from the battery;
- 3) The motor rotor needs to be shielded to prevent dust and foreign matters from entering;

Chapter 9 Unpacking instructions

Precautions: operate with care.

When unpacking, the system shall be in the positive direction according to the outer package identification.

After unpacking, check whether there is a packing list, check the items according to the packing list, and carefully check whether they are consistent with the physical objects.

附件 1: List of accessories

List of accessories			
No.	Item name	Number	Remarks
1	Operation and maintenance manual of Halo-2000 Generator	1	
2	Spark plug wrench	1	
3	Spark plug	1	

4	Fuel pipe (yellow oil inlet, 600mm long)	1	
5	Fuel pipe (black return, 600mm long)	1	

INSIGHTPEP.V.COM